

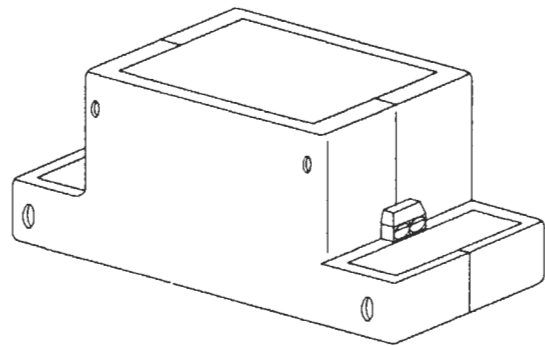

THE M901 ANALOG OUTPUT MODULE IS DESIGNED TO GENERATE 4-20 mA FOR USE IN CONTROLLING VARIOUS MIXING VALVES, DAMPERS, VARIABLE FREQUENCY DRIVES, AND ACTUATORS FOR PROPORTIONAL CONTROL. THE M901 INTERFACES DIRECTLY WITH ANY #8008LAN ClipperNet™ SERIES CONTROLLER WITH PWM OUTPUT AND THE XL9600 CONTROLLER, TO MODULATE ANY 4-20 mA ANALOG INPUT SIGNAL DEVICE.

- Programmable Analog Output vs Sensor Input curve (remotely via phone or locally via keyboard)
- Inexpensive and effective method of controlling various modulated and proportional valves, dampers, variable frequency drives, and many other applications
- Excellent linearity between the deviation from Set Point vs DC Output Current
- Small Din Rail mounted package
- User can program various slopes of output current response per given analog input range

4-20 mA ANALOG OUTPUT MODULE



#M901

GENERAL

The Solidyne M901 4-20 mA Output Module is designed to convert the PWM (Pulse Width Modulated) output signal available from a Solidyne Controller into a 4-20 mA analog current output. The Output vs Input slope is software programmable from the controller. When combined with other programs, a variety of control strategies are possible, such as generating different DC output currents at different times, as when programming night setback and holiday schedules, floating control setpoints and resettable setpoints.

Programming the M901 output via the Clipper or XL9600 is simple and straightforward. Using either the Floating PWM setpoint or Resettable PWM setpoint in the ClipperNet/XL or XL9600, or the "Hidden" PWM setpoint in other ClipperNet LAN controllers, the temperature (or other input) value determines the Output Current vs Input Value response curve. Gain and Offset are also programmable via the controller.

The M901 is optically isolated for reliable and safe operation, utilizing the most advanced solid state circuit design. The M901 requires a 24 VAC supply which should be readily available from existing control circuitry. The module's internal circuitry is isolated from the 24 VAC supply. The output is a floating isolated 4-20 mA signal, and is short-circuit protected. One M901 can control several actuators wired in series.

SPECIFICATIONS

ELECTRICAL

- SUPPLY:** 24VAC +/-15% @ 50mA
- INPUT:** 12VDC PWM (Pulse Width Modulated) signal @ 10mA
- OUTPUT:** LOW LEVEL; 4 mA, +/- 0.1 mA
HIGH LEVEL; 20 mA, +/- 0.1 mA

Output current level is determined by the input vs output programming in the controller. (Both internal offset and gain adjustments are preset at the factory.)

PROTECTION: Input signal is optically isolated.
The output is short-circuit protected.

AMBIENT TEMPERATURE: -20°F to +140°F

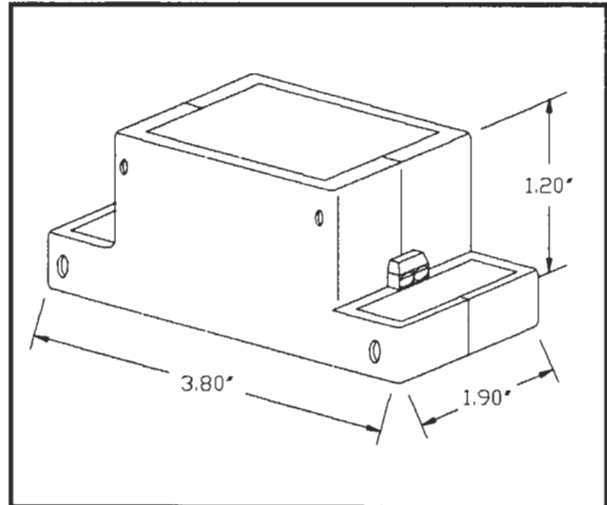

Fig. 1, Dimensions

MECHANICAL

DIMENSIONS: 3.80"L x 1.90"W x 1.20"H (See Fig. 1)

BODY: ABS plastic

CONNECTIONS: 4-position terminal strip for supply and input, 2-position terminal strip for output.

INSTALLATION

CAUTION

BEFORE INSTALLING OR REMOVING THE M901 MODULE, DISCONNECT POWER TO PREVENT EQUIPMENT DAMAGE OR PERSONAL INJURY.

1. Read installation instructions carefully. If these instructions are not followed equipment damage or personal injury may result.
2. Discharge any static you may have accumulated by touching a good earth ground before touching any components.
3. Check the ratings in the specifications and verify that this product will meet the requirements of your application.
4. This product should be installed by a trained, qualified service technician.
5. After the installation is complete, be sure to check the system out for proper operation.

MOUNTING / LOCATION

The M901 is designed to be mounted near the equipment being controlled for ease of wiring, and easily snaps onto a standard DIN rail. Make sure that the M901 is not exposed to direct outside environment such as rain, direct sunlight, etc. Keep in mind that it is generally better to keep the wiring from the DC output of the M901 to the load as short as possible, as the distance between the Clipper and the M901 can be up to 3000 feet.

WIRING with ClipperNet

The M901 has two terminals which must be wired to a Solidyne controller capable of a PWM output. A rectifier has been added to the input circuitry of the M901 so that the polarity (OUT and IN/OUT COM) in wiring from the controller to the M901 is not important (See Fig. 2). Typically, a twisted-pair of 18 AWG wires should be used. Shielding is not necessary under most conditions.

NOTE: The wiring from the Clipper does not have to be shielded and can be up to 3000 feet. A twisted pair of 18 AWG wire is recommended for most applications.

WIRING with XL9600

The M901 has two terminals which must be wired to an STB Transition Block Module in order to properly interface the XL9600 Controller. The STB is a straight through connection from the XL9600 ICS Board's 6 conductor RJ11 terminals to a 6 position terminal block.

The STB connects and allows access to all 6 positions of the ICS Board's individual female RJ11 "J" terminals. Using a STB connected to a "J" terminal with a DO and C(OUT) configuration, the terminals of the M901 connect to the DO output and the C(OUT) terminal on the STB (See fig. 3). Because of the rectifier added to the input circuitry of the M901, polarity is not important. If DO and C(OUT) on the STB were reversed the M901 will still operate properly.

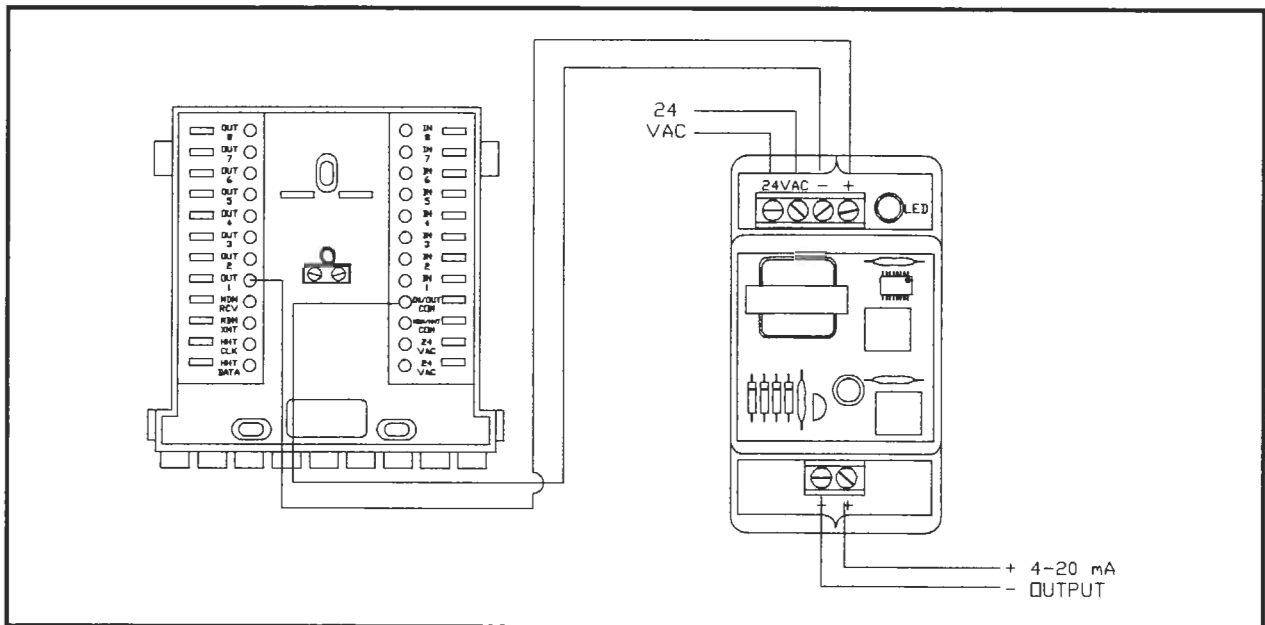

Fig. 2: M901 to Clipper Connection

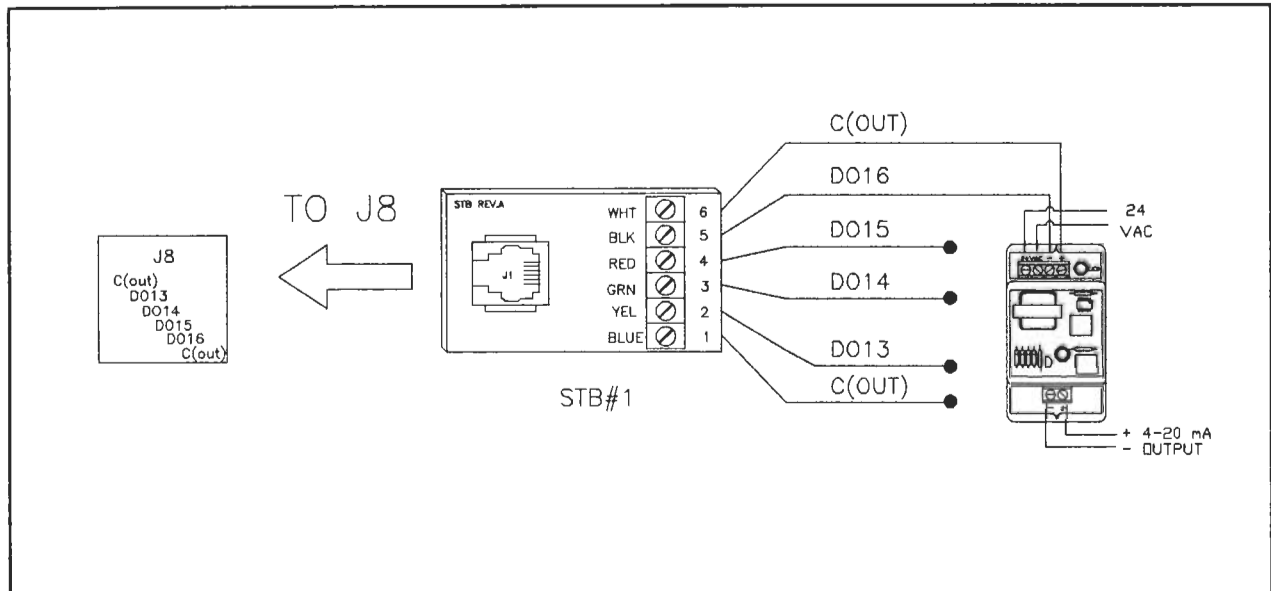

Fig. 3: M901 to STB Connection

OPERATION

Solidyne Controllers capable of generating a Pulse Width Modulation (PWM) output in conjunction with a PWM setpoints are used to modulate and control the M901. The outputs may be programmed to be a PWM output using a Miscellaneous Data Menu programming step. Select the FAST PWM OUTPUT select option to operate the M901. Once programmed to be a PWM output, that output will no longer respond to the Manual Load Toggle, the Override function, or any of the setpoints except the PWM types.

At power ON, the PWM outputs will produce a 50% cycle rate output. This is the default value when an output has been selected as FAST PWM but a program has not yet been entered. When a PWM setpoint is ACTIVE and the slave sensor reading is in the control range, the PWM output will modulate accordingly. If a PWM setpoint becomes INACTIVE at its end time, the PWM output will leave the cycle rate at the last known value when it became INACTIVE.

IMPORTANT

TO AVOID LOCKING A PWM LOAD IN AN UNDESIRABLE STATE, IT IS RECOMMENDED THAT PWM LOADS BE CONTROLLED 24 HOURS A DAY.

PROGRAMMING

The Clipper controller must be capable of generating a PWM output in order to control the M901. This includes the ClipperNet/XL, ClipperNet/PLUS and most other ClipperNet LAN controllers. The XL9600 controller is also capable of generating PWM signals to control the M901.

When programming a ClipperNet/XL or XL9600, either the Floating PWM setpoint or Resettable PWM setpoint could be used. The "resettable" function of either setpoint which uses a Master sensor to reset target values can be ignored if this feature is not desired. These programs offer the most flexible and precise control of the M901.

In the ClipperNet/PLUS as well as other ClipperNet LAN controllers, a "Hidden" PWM setpoint would be used. This is actually a Variable Analog Control setpoint which acts as PWM when its output is selected as FAST PWM.

In either case, the programming is straightforward. With the load polarity of the output specified (under Enter Miscellaneous Data) as ENERGIZED = OFF a 10% PWM signal would correspond to 5.6 mA and a 90% PWM signal would equal 18.4 mA from the M901. A change in the input value to the setpoint will cause a proportional change in the PWM output.

The maximum and minimum PWM values can be selected and associated with the input limits.

NOTE: *The M901 has been calibrated to output 4 mA at a PWM signal of 4% and to output 20 mA at 96%. Use 4% and 96% as your MINIMUM and MAXIMUM duty cycle rate should you need to range from 4-20 mA.*

This setpoint can be either direct or indirect acting. The basic program can further be "fine tuned" by changing the Update Rate, Maximum Change Rate and entering the Reset Function if desired.

Refer to the Controllers' Operations manual for further programming details.

NOTE: *Once an output is programmed to be a PWM output none of the control programs, parameters or features applicable to ordinary digital load control outputs are valid. If no program exists internally to the Controller but an output is chosen to be a PWM output, the output will be a 50% cycle rate which in the M901 will generate a 12 mA output, the midpoint between 4 to 20 mA. Therefore, it is important to program the Controller for both occupied and unoccupied hours for the desired analog output signal.*

CHECK OUT PROCEDURE

1) Apply power to the Controller. The M901 module should already be wired. The output of the Controller being used for the M901 should be selected for FAST PWM under the Miscellaneous Menu, and the LOAD POLARITY under the same menu should be selected to be OFF = ENERGIZED for most applications. Do not enter a PWM setpoint at this time. Refer to the Operations manual for details.

2) Verify the 24 VAC supply to the M901 module.

3) Verify that the LED located next to the input terminal on the M901 is flashing at approximately 5 Hz.

4) If the Controller and the M901 are mounted some distance from each other, an assistant would be helpful for this procedure.

Under the EXAMINE LOGGED DATA menu of the ClipperNet/PLUS, ClipperNet/XL or XL9600, select the "PWM OUTPUT DUTY CYCLE VALUE" menu. Select the output to which the M901 is connected. This menu will allow you to see the PWM value of that output, as well as "override" it to a known test value. The display should now show 50%, which if no program was entered, would be the default value.

NOTE: *If a program were entered this step would not be possible as the program would take control of the output and not allow an override value.*

With the PWM output at 50%, check the M901 output and load for correct operation. At 50% PWM, the output should be at 50%, or in this case, 12 mA. Enter a test PWM value into the Controller and observe the M901 and load operation. For example, entering a value of 25% would cause an output of 8 mA; a value of 80% would cause an output of 16.8 mA, and so on.

5) Finally, enter the actual operating setpoint and observe the system for correct operation.

7/90

ORDERING KEY

Refer to your authorized SOLIDYNE Wholesaler or Blue Sheet price list for complete ordering information.

If you have additional questions or need further information related to this product or any other SOLIDYNE products, call (800) 648-3980 for order information, or call (708) 394-3333 for technical help and support.

1. Order Part # M901.
2. For use with the Solidyne #8008LAN series of ClipperNet controllers capable of PWM programming..
3. For use with Solidyne XL9600 Controller (Part #STB required).